

# Fixing Instructions for SDV-200 Continuous Dry Verge for Slate

This Slate Dry Verge System is designed for use with most natural and man made slates of up to a maximum 6mm in thickness and care should be taken if mechanically fixing slates thicker than this

The Slate Dry Verge System is fitted to the top end of the battens and forms a fixing for the slate whilst covering the end of the battens

Expansion joints are provided and these details should be adhered to thus avoiding possible buckling or breaking during periods of hot or cold weather

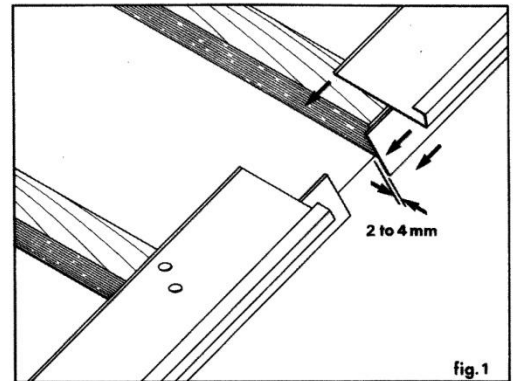

1. Trim ends of battens 2 to 4mm from edge of barge board or brickwork and ensure they are securely fixed
2. Fix first length of Dry Verge in to position using suitable galvanized nails as shown in fig. 1
3. Make sure that the end of the gutter will fit in a suitable position for discharge and if necessary using a fine toothed hacksaw trim this end of the Dry Verge to fit as required
4. Place the next section of Dry Verge in to position leaving an expansion gap of between 6 and 8mm as shown in fig. 2
5. Continue fitting the Dry Verge up to the apex of the roof
6. At the apex trim the Dry verge using a fine toothed hacksaw to fit neatly or if using the SDV-300 series Ridge End Cap leave a gap of between 15 to 20mm as shown in fig. 3
7. If a ridge tree or ridge batten is present trim the Dry Verge using a fine toothed hacksaw to leave a gap either side of 10mm as shown in fig. 4
8. It may also be necessary to cut the ridge tree or ridge batten back to fit the SDV-300 series Ridge End Cap if used
9. If the SDV-300 series Ridge End Cap is to be used it is useful at this point to mark the position of the top tiling batten on the Dry Verge profile to assist when fixing this product in to the end of the batten
10. When fitting the slates in to the Dry Ridge profile care must be taken to avoid bending the profile too much with excessive force and whilst the profile is extremely flexible, support should be provided to avoid breaking
11. If the SDV-300 series Ridge End Cap is to be used follow the fixing instruction supplied with the product

